



MLC 60 Series • Setup Guide

for the MLC 62 RS EU and the MLC 62 RS MK

IMPORTANT: Go to www.extron.com for the complete user guide and installation instructions before connecting the product to the power source.

The Extron MLC 62 RS EU and the MLC 62 RS MK are keypad controllers for use in classrooms and meeting facilities. The EU model attaches to a single size European electrical junction box with a 60 mm mounting center; the MK model mounts to a single size MK junction box. The controllers have backlit soft touch buttons and can control common AV functions, including power, input switching, and volume. Both models provide RS-232 serial and IR ports for universal display control. A digital input and two relays enable monitoring and controlling of other devices in the room. Both models have six-button and eight-button options.

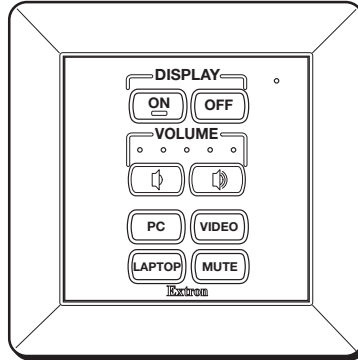

MLC 62 RS EU

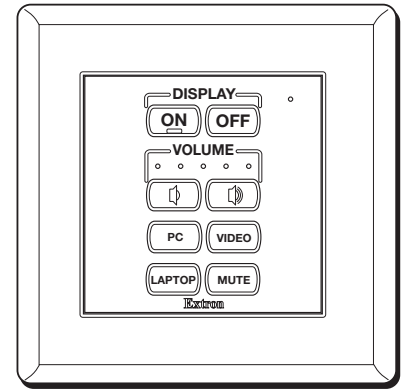

MLC 62 RS MK

NOTES:

- Installation and service must be performed by authorized personnel only.
- For full installation, configuration, and operation details, see the *MLC 60 Series User Guide*, available at www.extron.com.

Installation Steps

1. Prepare the installation site.

The MLC 62 EU and MK controllers can be installed in a standard EU or MK one-gang electrical wall box:

- Install the electrical box, following the instructions provided with it.

CAUTION: Ensure that the junction box is properly grounded.

- Prepare and pull the cables through the electrical box.

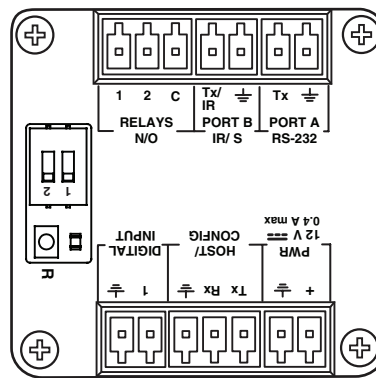

Rear Panel

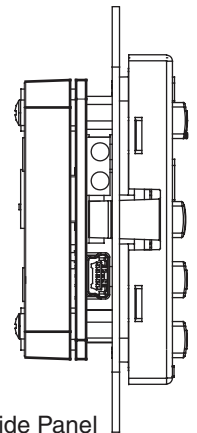

Left Side Panel

2. (Optional) Change the faceplate and buttons as needed.

- Remove the faceplate from the MLC module as follows:
 - On the right and left edges of the faceplate are two pairs of slots, into which two small tabs on either side of the MLC fit. Insert the flat end of a small screwdriver into each side slot (as shown at right) and press inward until the tab is released from its slot.
 - Lift the faceplate off the MLC circuit board.
- If desired, replace the buttons in the faceplate as follows:
 - From the front of the faceplate, press the button membrane to be replaced backward through its faceplate openings until it comes free. If replacing the faceplate, repeat this step until all the buttons are removed.

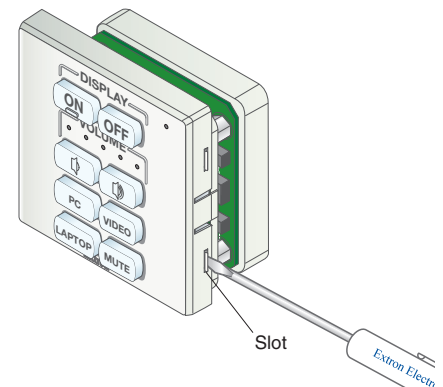

Slot

Extron Elect

- On the back of the faceplate, set the new button membrane at the desired location, with the two pegs in the upper-left and lower-right corners of the membrane in the faceplate holes at opposite corners of the row (see the illustrations at left and at right). Press the pegs and buttons of the membrane into the faceplate.

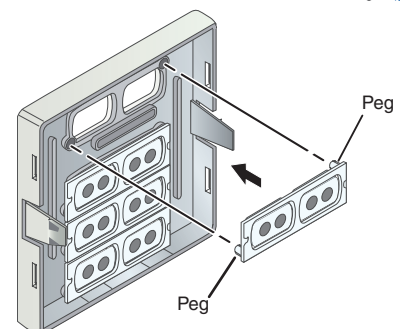

Peg

Peg

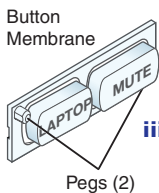

Button Membrane

Pegs (2)

- Repeat step 2 b as needed.

MLC 62 EU and MLC 62 MK • Setup Guide (Continued)

- c. Reattach or replace the faceplate as follows (see the illustration at right):
 - i. Making sure that both the MLC and the faceplate are upright, hold the MLC with its circuit board against the back of the faceplate, aligning the two tabs on each side of the MLC with the two slots on each side of the faceplate.
 - ii. Each tab has a ridge that must snap into a slot on the side of the MLC. Press the MLC into the faceplate until the ridges on all four tabs snap into place.

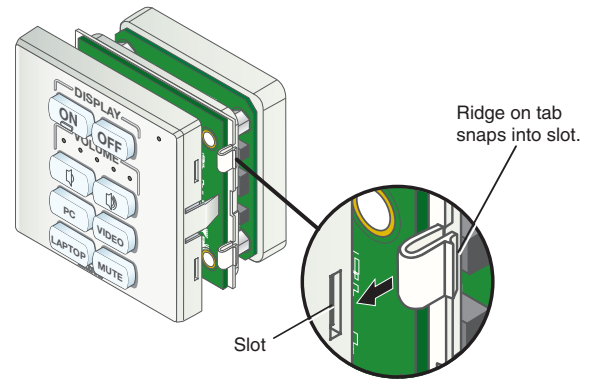

3. Attach the metal mounting bracket to the junction box.

- a. Place the metal bracket on the electrical box, aligning the slotted holes in the bracket with the round holes on the box.

NOTE: To keep the MLC securely in place and prevent it from being easily pulled from its mounting, ensure that the side of the bracket with the word "Front" engraved on it faces **out** (away from the electrical box). If you want to be able to remove the MLC easily from its mounting, attach the bracket with "Front" facing **inward**, toward the junction box.

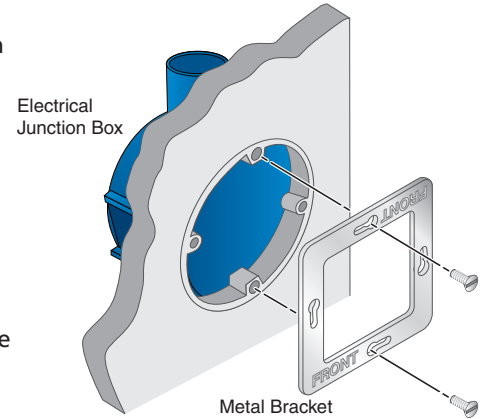

- b. Insert two of the included screws in the slots at the top and bottom of the bracket as shown at right.
- c. Tighten the screws to secure the bracket to the mounting surface.

4. Connect the cables to the MLC rear panel ports.

Attach the cables and IR emitters to the rear panel of the MLC and to the display device or switcher as required.

- **Port A RS-232:** Connect a display device or switcher to this serial port to control the device via RS-232 (see the illustration at right).

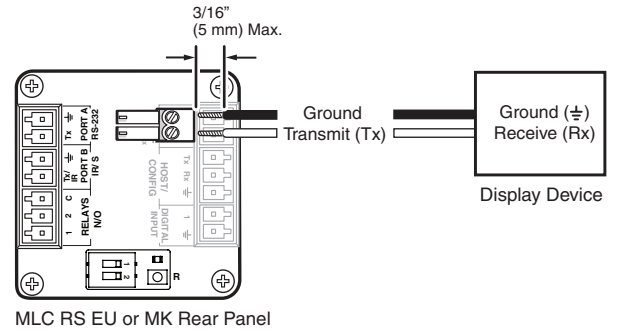

- **Port B IR/S:** Connect a display device, switcher, or up to two IR emitters to this port (see the illustration at right). You can configure this port for either serial or IR communication using the MLC 60 Series Configuration Program.

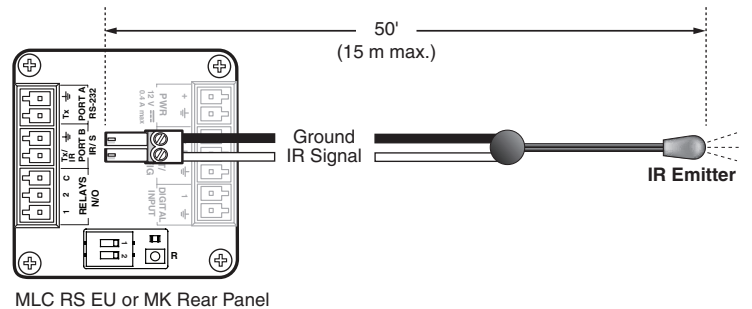

- **Relay ports:** The relay ports provide connections for two relays. Connect one or two devices (such as a low-voltage controller and a motorized screen, shown in the example at right) to this port. The relay ports are normally open and rated for 24 VDC, 1 A).

NOTE: If you use both relay ports, connect the ground wires of **both** devices to common pin 3.

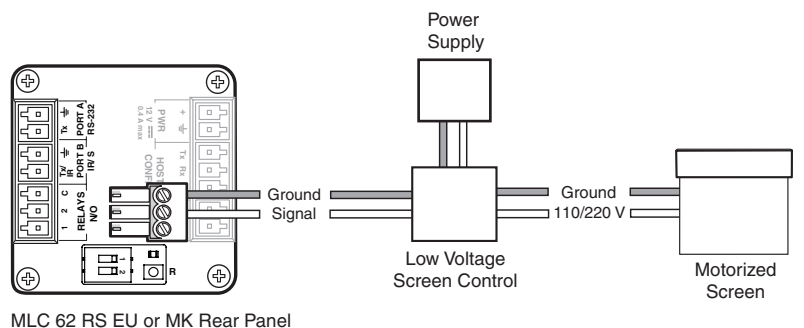

- **Digital Input port** — Connect a switch or sensor to this port to control other devices in the room that are connected to the MLC serial, IR, or relay ports. The port monitors the high and low states of the connection between the switch or sensor and the connected device. For the voltage thresholds, a voltage below 1.0 VDC is considered **logic low**, and a voltage above 1.5 VDC, **logic high**. When a threshold between the states is crossed (from high to low and vice versa), the selected action occurs.

By default, this port is configured with a +5 VDC pull-up resistor for use with basic non-powered switches. If the device being connected has its own power source, configure the port to disable the pull-up mode (see the configuration program help file for port setup procedures). To wire this port, see the example above.

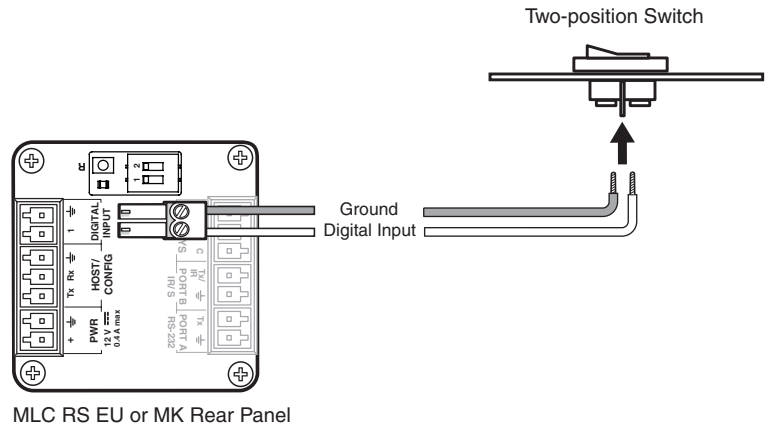

5. Connect and apply power.

Connect the included power supply to the MLC Pwr connector as shown at right, then connect power to all devices in the system.

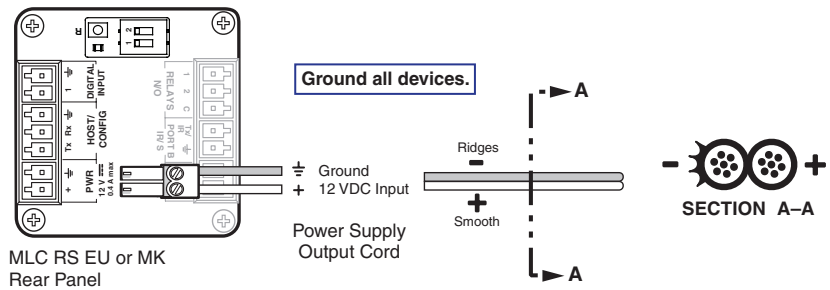

6. Connect the MLC to the computer.

Use either of the following methods:

- Connect a USB A-to-USB mini B cable between the **USB configuration port** on the MLC side panel and a USB port on your computer as shown at right; **or**
- Wire an RS-232 cable to the provided 3-pole connector and connect it between the MLC **Host/Config port** and the computer serial port, as shown below.

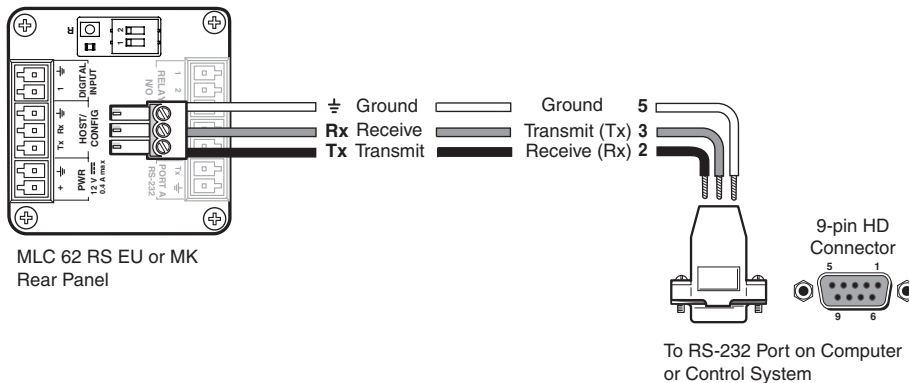
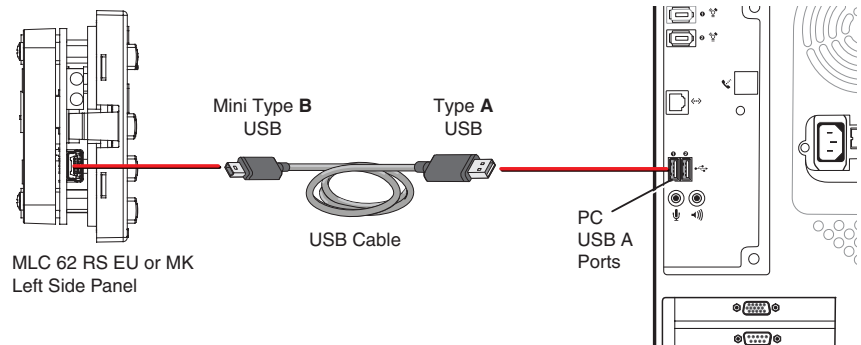

7. Configure the MLC buttons and ports (see the *MLC 60 Series Configuration Program Help File* for the procedures).

- Load and install the configuration software to your computer from the Extron website or the provided DVD.
- Obtain device drivers. Drivers for the devices that will be connected to the MLC rear panel IR and serial ports can be obtained from the provided MLC software DVD or downloaded from the Extron website at www.extron.com. You can also obtain them using the configuration software if an Internet connection is available.
- Upload the configuration to the MLC.

8. **Test the system** to ensure that the MLC is functioning properly.
9. **Mount the MLC.**
Before mounting the MLC to a wall or furniture, make sure that all device cables are connected to the MLC rear panel. Disconnect power at the source from all devices in the system.
 - a. Align the MLC wall frame to the metal mounting bracket, which you attached to the mounting surface in step 3.
 - b. Holding the wall frame in place on the bracket, press the MLC into the frame until the two tabs on either side of the unit snap into the opening of the metal bracket, holding the MLC in place.

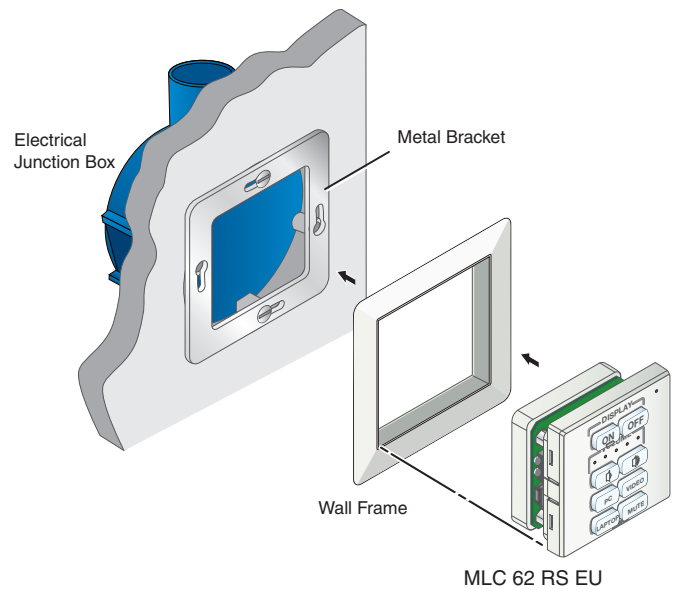

Mounting the MLC 62 EU in a Raceway Using a Spacer (Optional)

If you are experiencing difficulty with the MLC staying in place when installed in a cable raceway, this may be due to a gap between the metal mounting bracket and the wall frame. When this gap exists, the tabs on the sides of the MLC do not reach the metal mounting bracket and the MLC does not snap completely into the metal bracket.

You can remedy this situation by installing a spacer (provided with the MLC) between the metal mounting bracket and the rim of the junction box. This spacer appears very similar to the metal mounting bracket, except that it has holes instead of slots for the mounting screws, is engraved with the words "Optional Spacer" and "Place behind bracket," and has a slightly larger center opening than the metal mounting bracket.

1. Mount the electrical box in the raceway.
2. Attach the spacer to the electrical box by inserting two of the included screws in the holes at the sides of the spacer. Leave the screw heads protruding approximately 1/8 inch from the surface of the spacer.
3. With the "Front" label facing toward you, place the metal mounting bracket onto the spacer so that the screw heads pass through two of the slotted holes in opposite sides of the bracket.

NOTE: Ensure that the surface of the mounting bracket containing the word "Front" is facing **out** (away from the spacer and junction box).

4. Rotate the mounting bracket as necessary to ensure that the MLC will be positioned straight on the mounting surface and not skewed to either side.
5. Tighten the screws to secure the bracket to the spacer.
6. Pull the cables through the electrical box and the wall frame.
7. Disconnect power from all devices at the source and connect all cables to the MLC.
8. Align the wall frame with the metal mounting bracket on the mounting surface.
9. Press the MLC into the wall frame until the unit snaps into place.

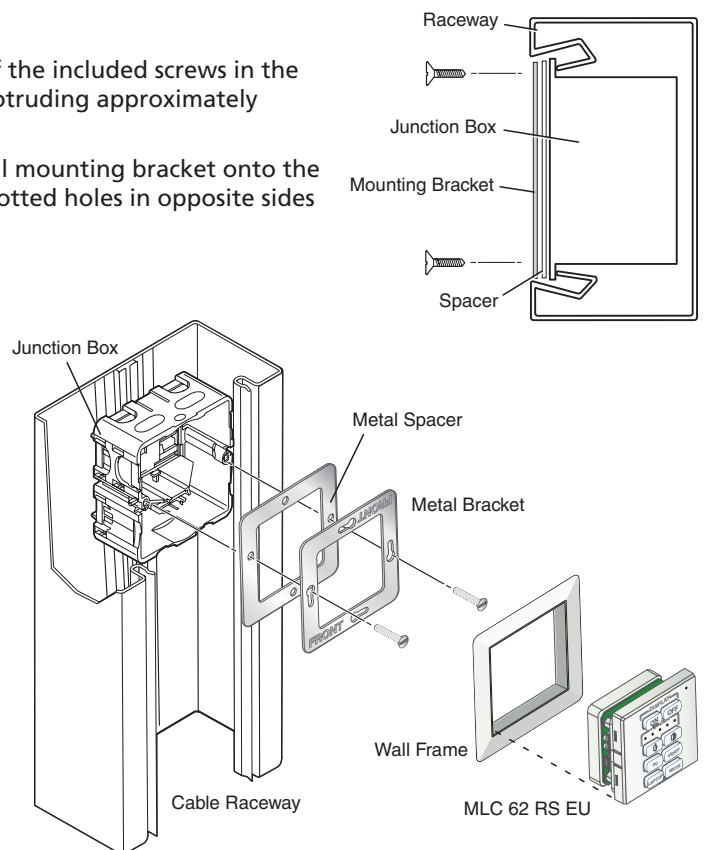

Extron Headquarters +1.800.633.9876 (Inside USA/Canada Only) Extron USA - West Extron USA - East +1.714.491.1500 +1.919.863.1794 +1.714.491.1517 FAX +1.919.863.1797 FAX	Extron Europe +800.3987.6673 (Inside Europe Only) +31.33.453.4040 +31.33.453.4050 FAX	Extron Asia +800.7339.8766 (Inside Asia Only) +65.6383.4400 +65.6383.4664 FAX	Extron Japan +81.3.3511.7655 +81.3.3511.7656 FAX	Extron China +4000.398766 Inside China Only +86.21.3760.1568 +86.21.3760.1566 FAX	Extron Middle East +971.4.2991800 +971.4.2991880 FAX	Extron Korea +82.2.3444.1571 +82.2.3444.1575 FAX	Extron India 1800.3070.3777 Inside India Only +91.80.3055.3777 +91.80.3055.3737 FAX
--	--	--	---	--	---	---	--